

Project Name: Gen 3 5040 & 4240 Mobile Stage Approval

Project Number: 21-0797, 23-0174, 24-0071



5040 Gen3 RATING DRAWINGS

ISSUED 2024-08-23

COPYRIGHT © 2024

THIS DOCUMENT IS THE PRODUCT AND EXCLUSIVE PROPERTY OF SCHAEFER. NEITHER THE DOCUMENT NOR THE INFORMATION IT CONTAINS MAY BE COPIED OR USED FOR OTHER THAN THE SPECIFIC PURPOSE FOR WHICH IT WAS PREPARED, WITHOUT THE WRITTEN CONSENT OF SCHAEFER.

APEX STAGES GEN3 5040

UNFOLDING THE POSSIBILITIES

WELCOME TO "BEAST MODE"

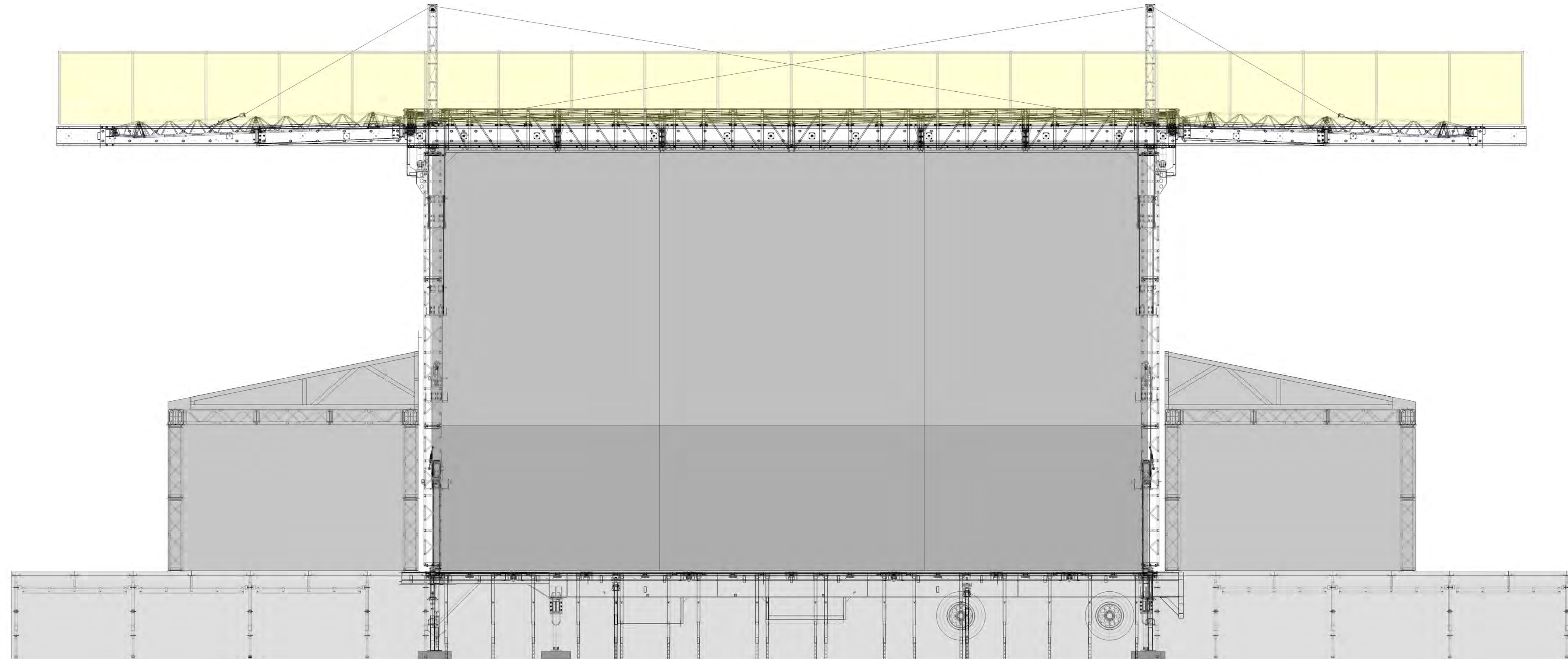

TOTAL WEIGHT CAPACITY OF ROOF STRUCTURE: 102,000 LBS

ULTIMATE WIND RATING WITHOUT WALLS: 90 MPH SERVICE LEVEL / 115 MPH ULTIMATE LEVEL

**THESE WIND SPEEDS ARE MODIFIED WITH A FACTOR OF 0.75 FOR USE DURATIONS OF LESS THAN 6 WEEKS,
IN ACCORDANCE WITH ANSI E1.21 AND ASCE 37. EQUIVALENT DESIGN SPEEDS = 67.5MPH SERVICE LEVEL / 86MPH ULTIMATE LEVEL**

APEX STAGES GEN3 5040

UNFOLDING THE POSSIBILITIES

"BEAST MODE" TRAILER VIEW

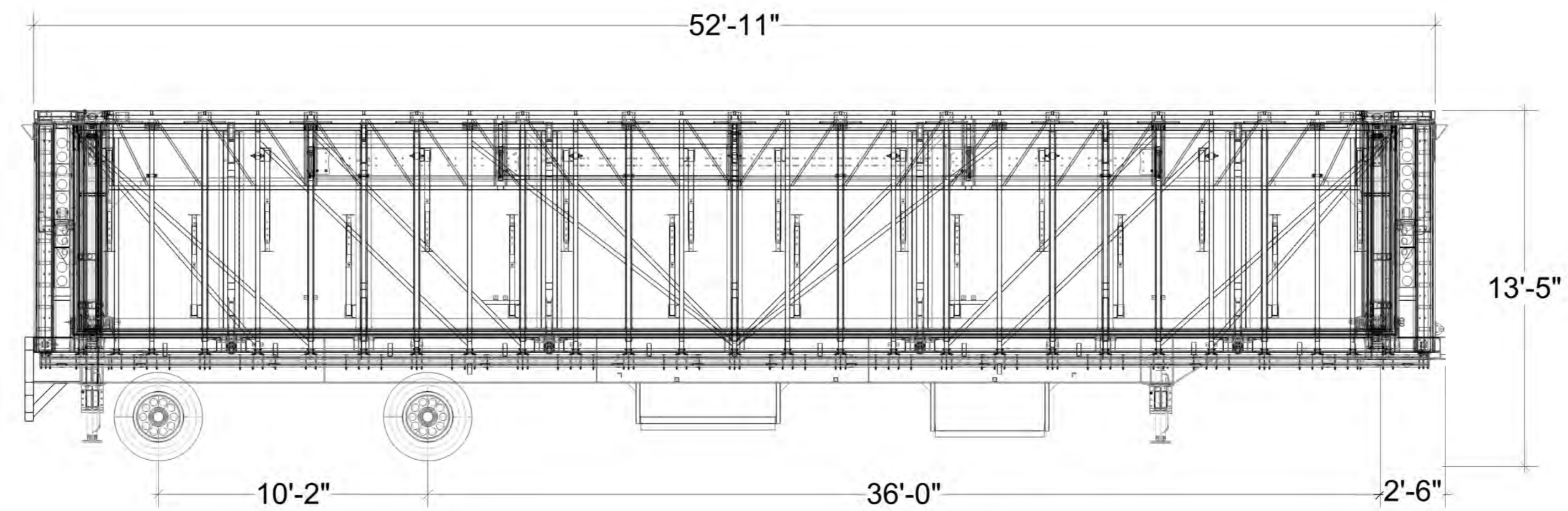

TOTAL WEIGHT EMPTY: 57,000LBS
TOTAL WEIGHT BASIC MODE WITH ADDS: 60,300LBS
TOTAL WEIGHT ON BACK SPITS: 39,600LBS
TOTAL WEIGHT ON KINGPIN: 20,700LBS
ESTIMATED WEIGHT OF SINGLE SLEEPER TRACTOR, FUEL, DRIVER: 19,500LBS
GROSS WEIGHT WITH TRACTOR: 79,800LBS
STANDARD KING PIN POSITION OF 30 INCHES
"NON STANDARD" AXEL SPLIT

APEX STAGES GEN3 5040

UNFOLDING THE POSSIBILITIES

"BEAST MODE" WITH COVERED WORK WINGS
FRONT VIEW

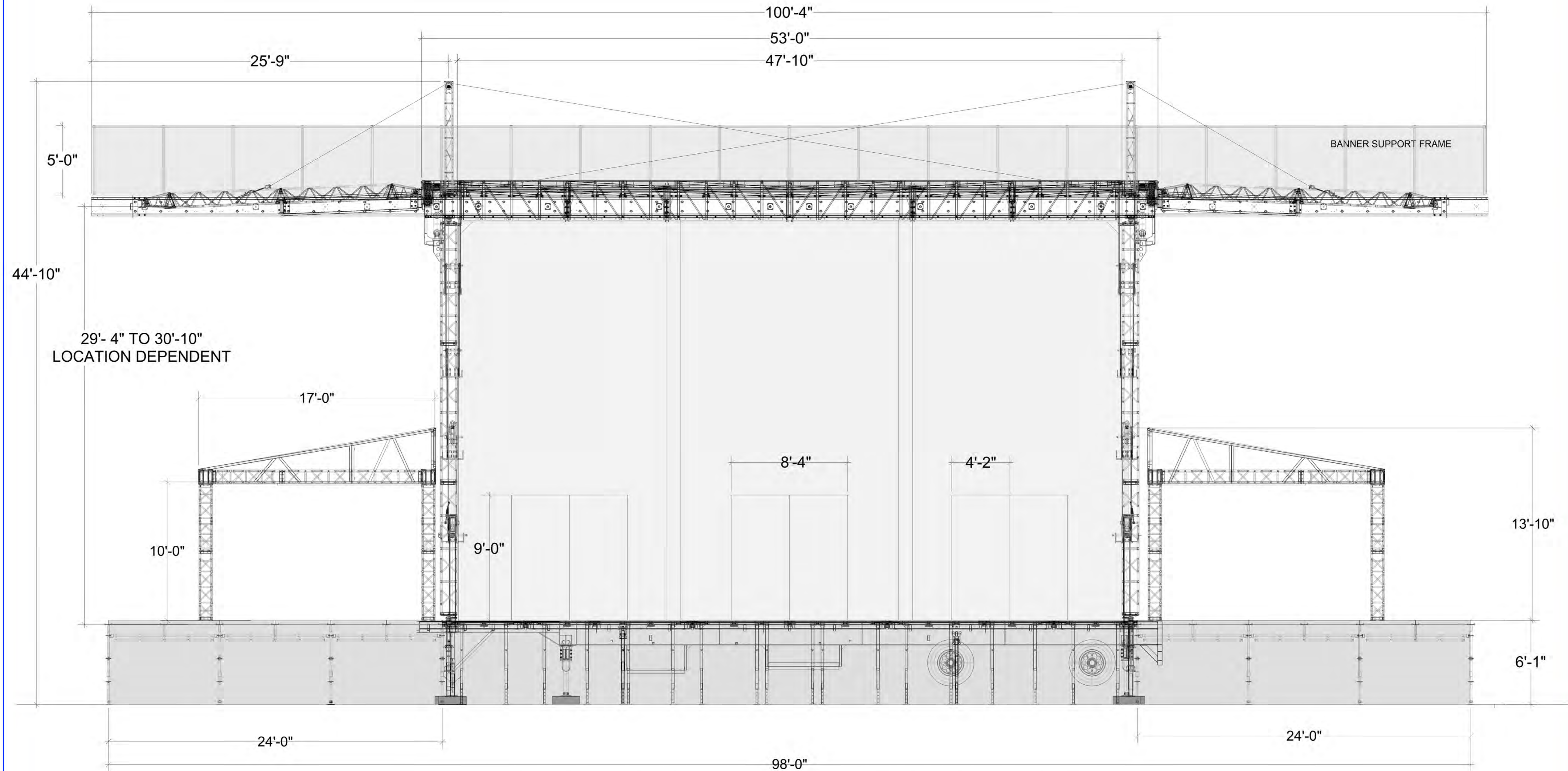

STANDARD OPTIONS: 120 4X8 DECKS, 10 CAN BE ROLLING RISERS, TWO 16 FT TRUCK RAMPS, AND 4 STAIR UNITS

APEX STAGES GEN3 5040

UNFOLDING THE POSSIBILITIES

"BEAST MODE" SIDE VIEW

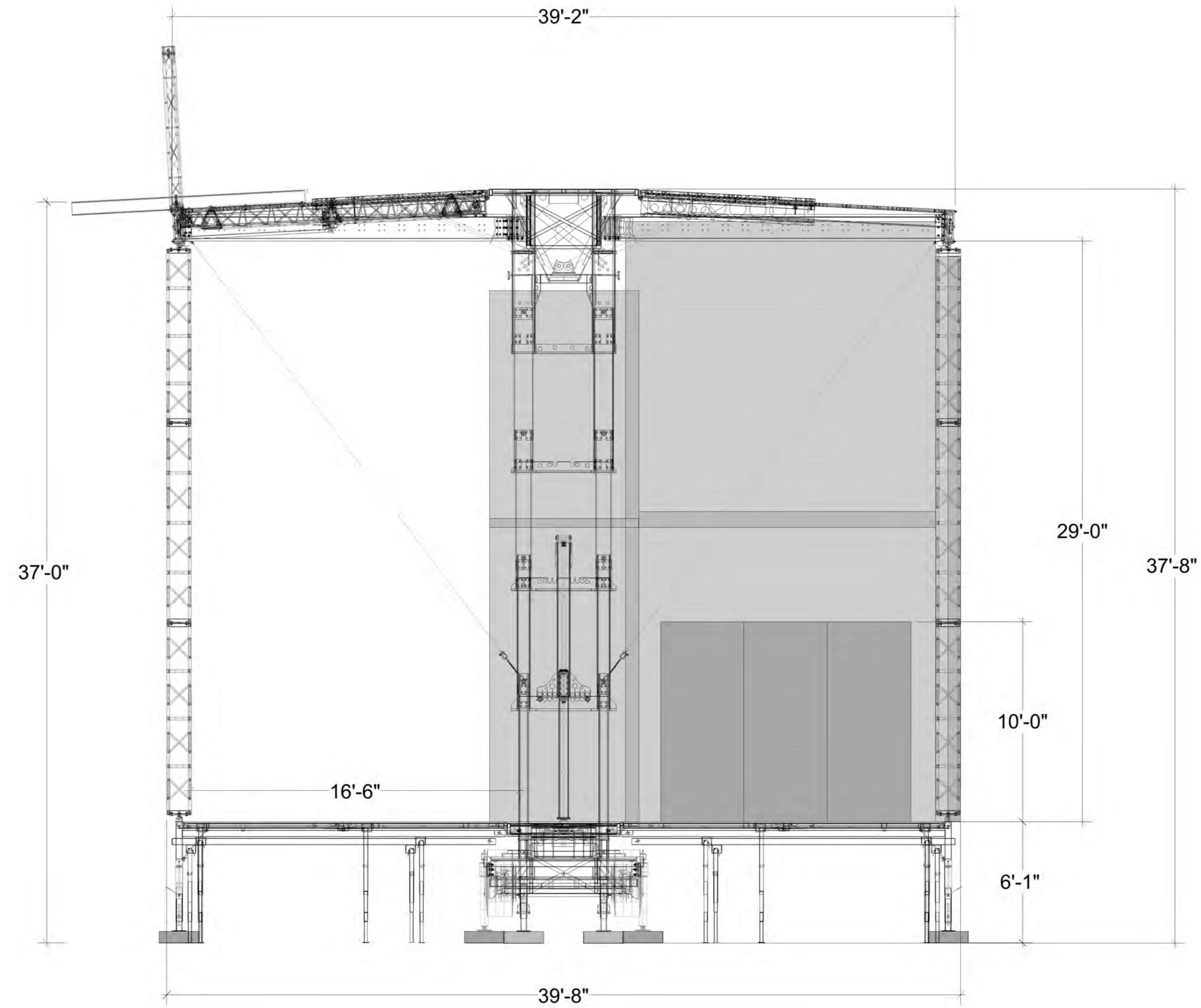

APEX STAGES GEN3 5040

UNFOLDING THE POSSIBILITIES

"BEAST MODE" DIMENSIONS AND WEIGHTS

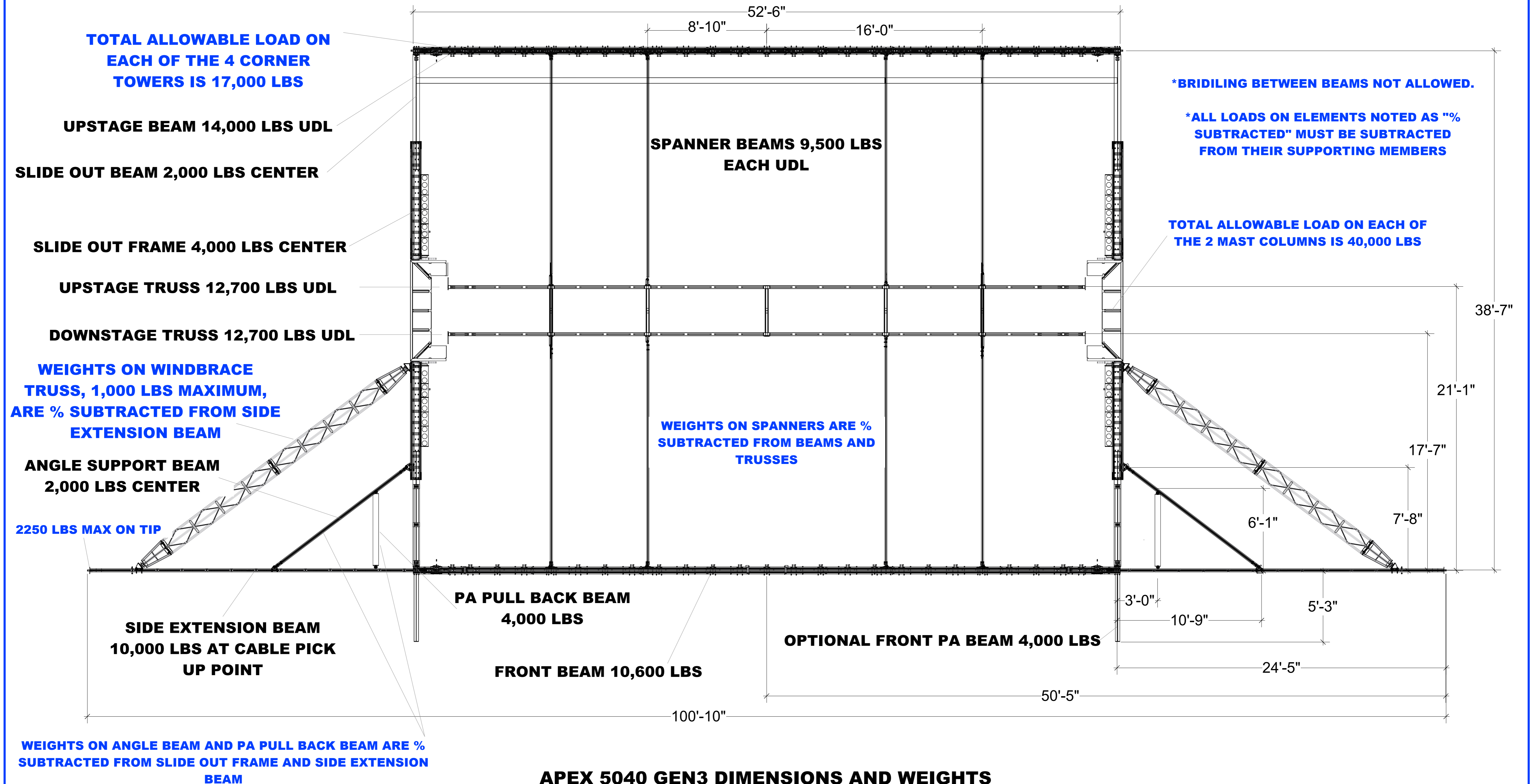

APEX 5040 GEN3 DIMENSIONS AND WEIGHTS
TOTAL WEIGHT CAPACITY OF ROOF STRUCTURE 102,000 LBS
TOTAL WEIGHT CAPACITY OF COLUMNS AND TOWERS IS 148,000 LBS

APEX STAGES GEN3 5040

UNFOLDING THE POSSIBILITIES

"BEAST MODE" POINT LOADS ON BEAMS

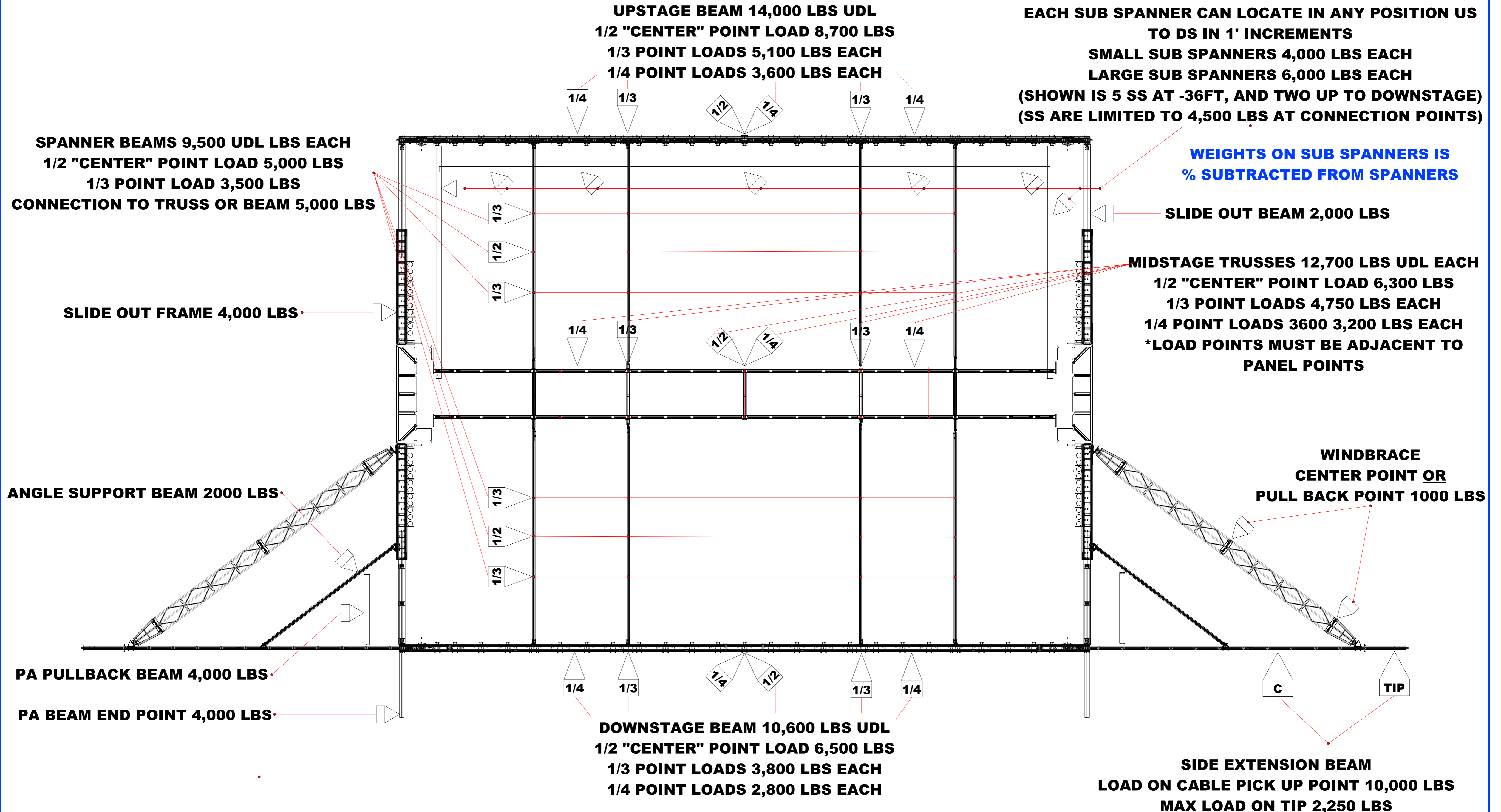

APEX STAGES GEN3 5040

UNFOLDING THE POSSIBILITIES

BEAST MODE OTHER
CONFIGURATIONS AND OPTIONS

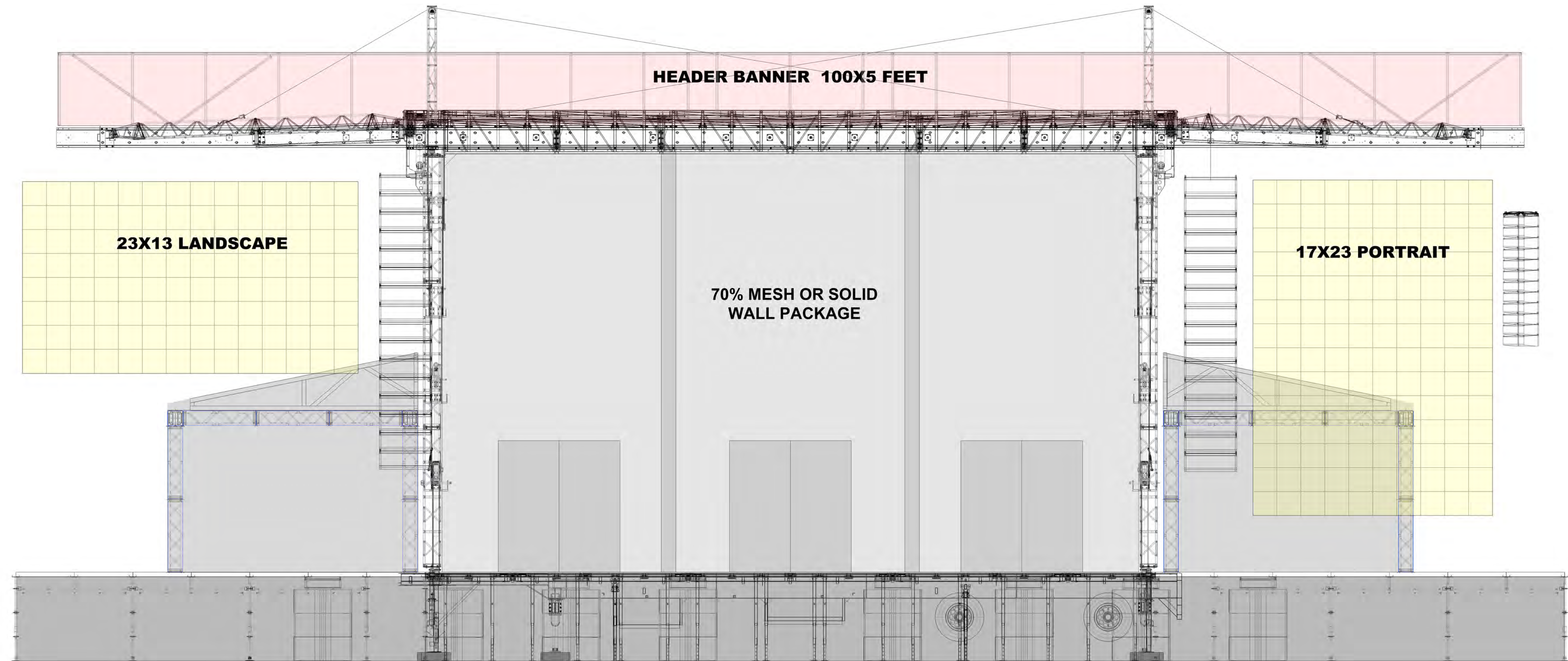

EXAMPLE #1
PA ON FRONT HANG POINTS, LANDSCAPE

EXAMPLE #2
PA HANG ON SIDE SLIDE OUT, PORTRAIT, OUTFILLS

APEX STAGES GEN3 5040

UNFOLDING THE POSSIBILITIES

"BASIC MODE EXTENDED" FRONT VIEW

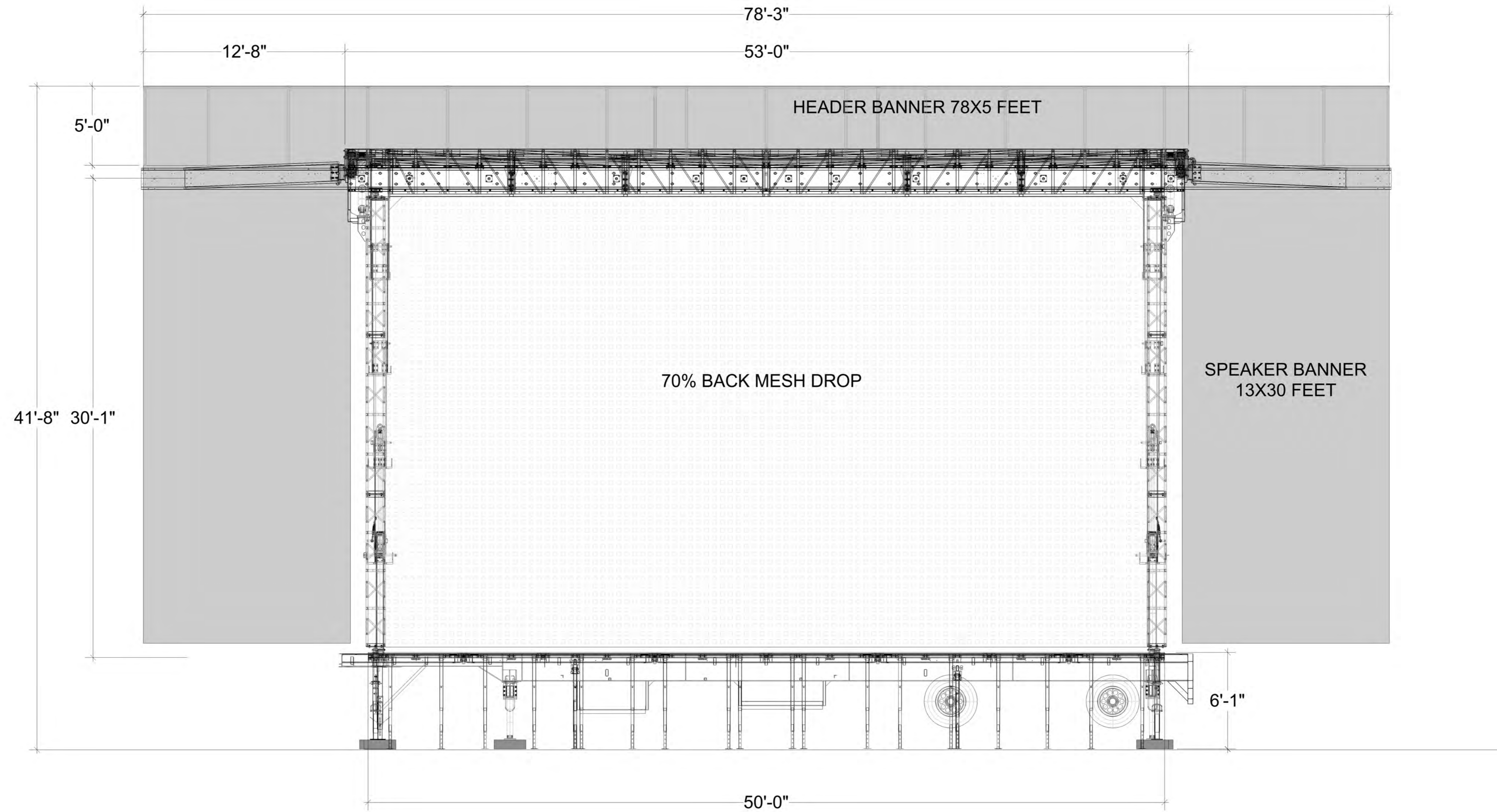

APEX STAGES GEN3 5040

UNFOLDING THE POSSIBILITIES

"BASIC MODE EXTENDED" SIDE VIEW

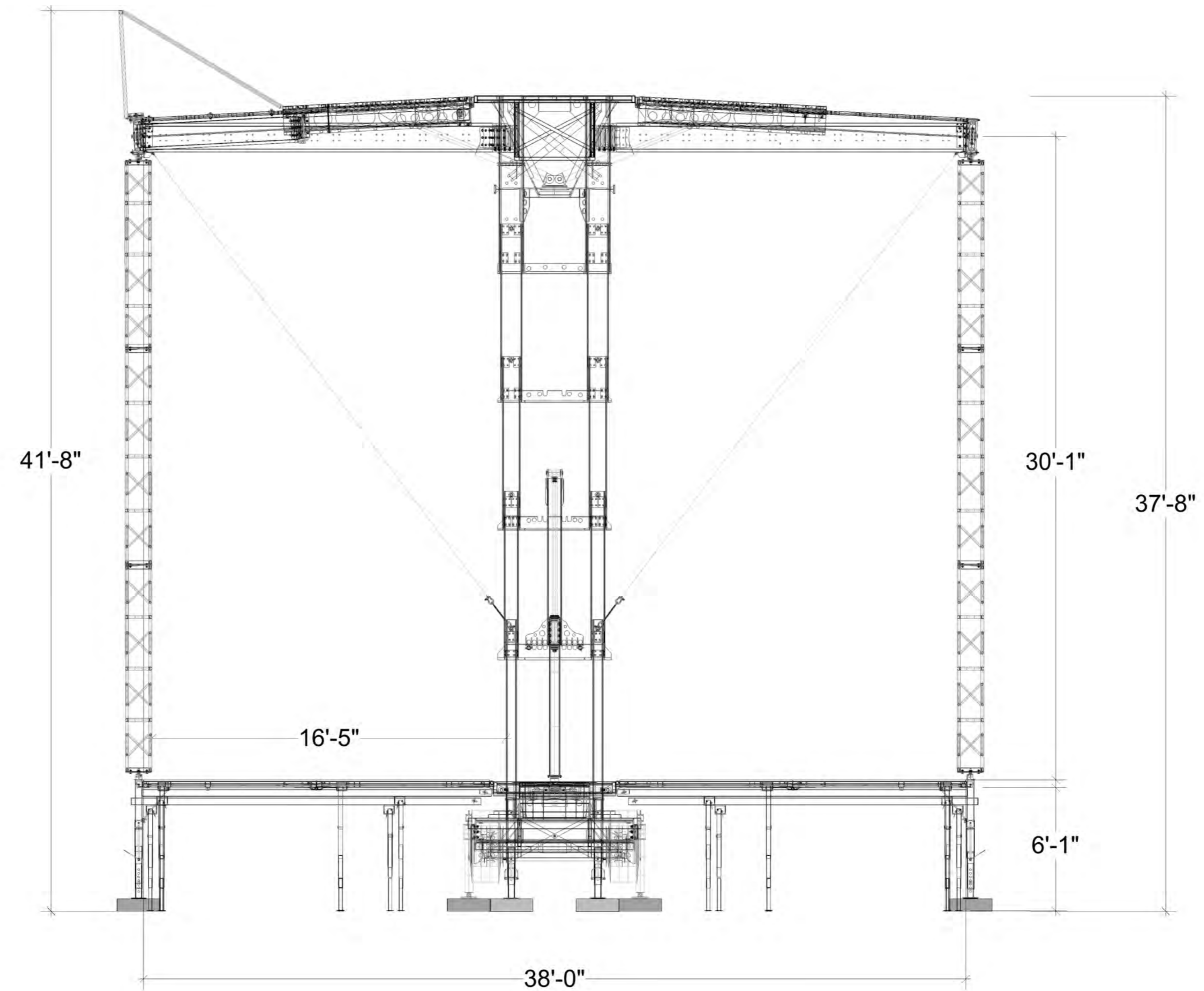

APEX STAGES GEN3 5040

UNFOLDING THE POSSIBILITIES

**"BASIC MODE EXTENDED"
DIMENSIONS AND WEIGHTS**

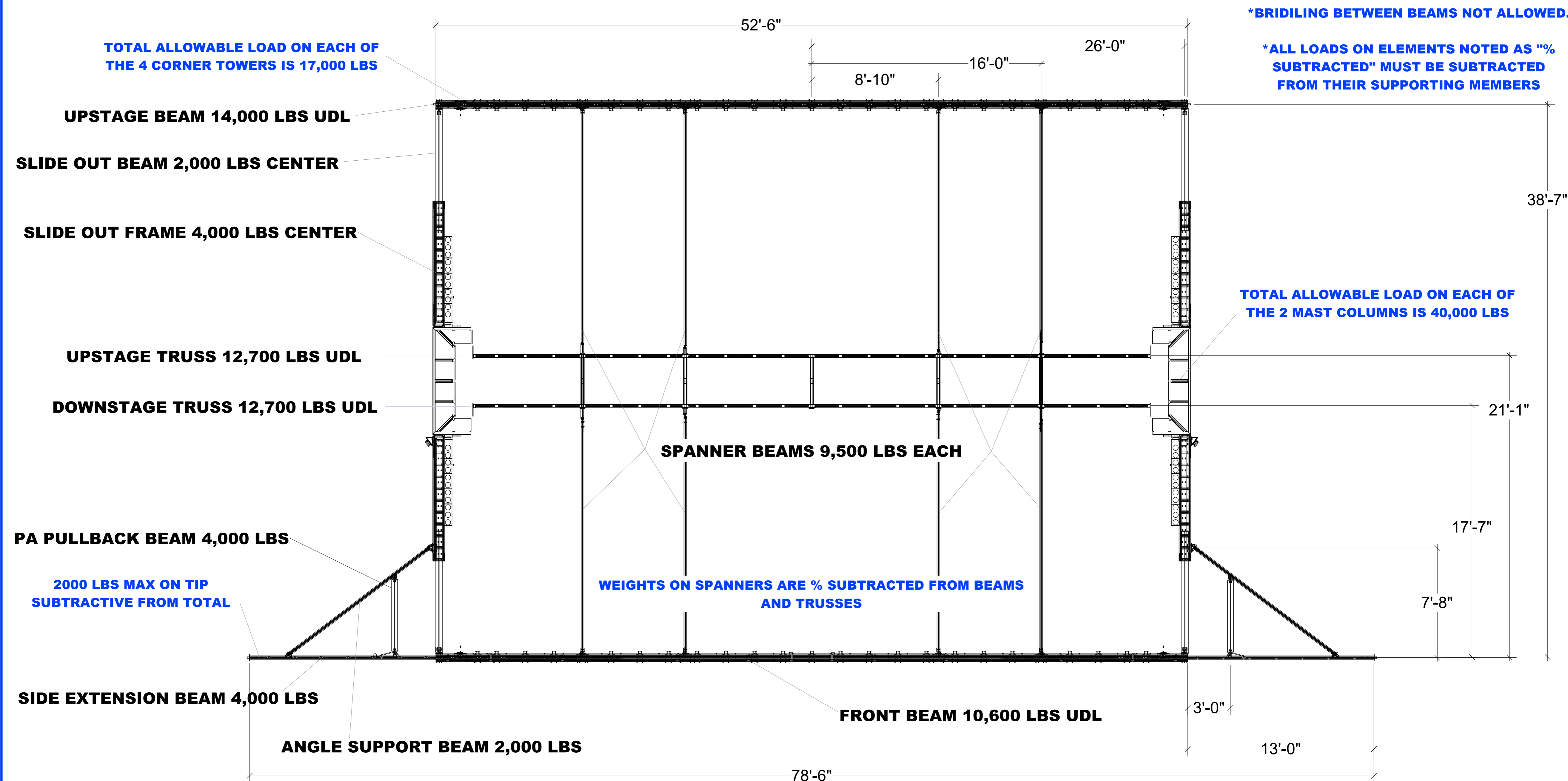

APEX 5040 GEN 3 DIMENSIONS, AND WIEGHTS
TOTAL WEIGHT CAPICITY OF ROOF: 82,000 LBS
TOTAL WEIGHT CAPCITY OF COLUMNS AND TOWERS IS 148,000 LBS

APEX STAGES GEN3 5040

UNFOLDING THE POSSIBILITIES

"BASIC MODE EXTENDED" OTHER CONFIGURATIONS AND OPTIONS

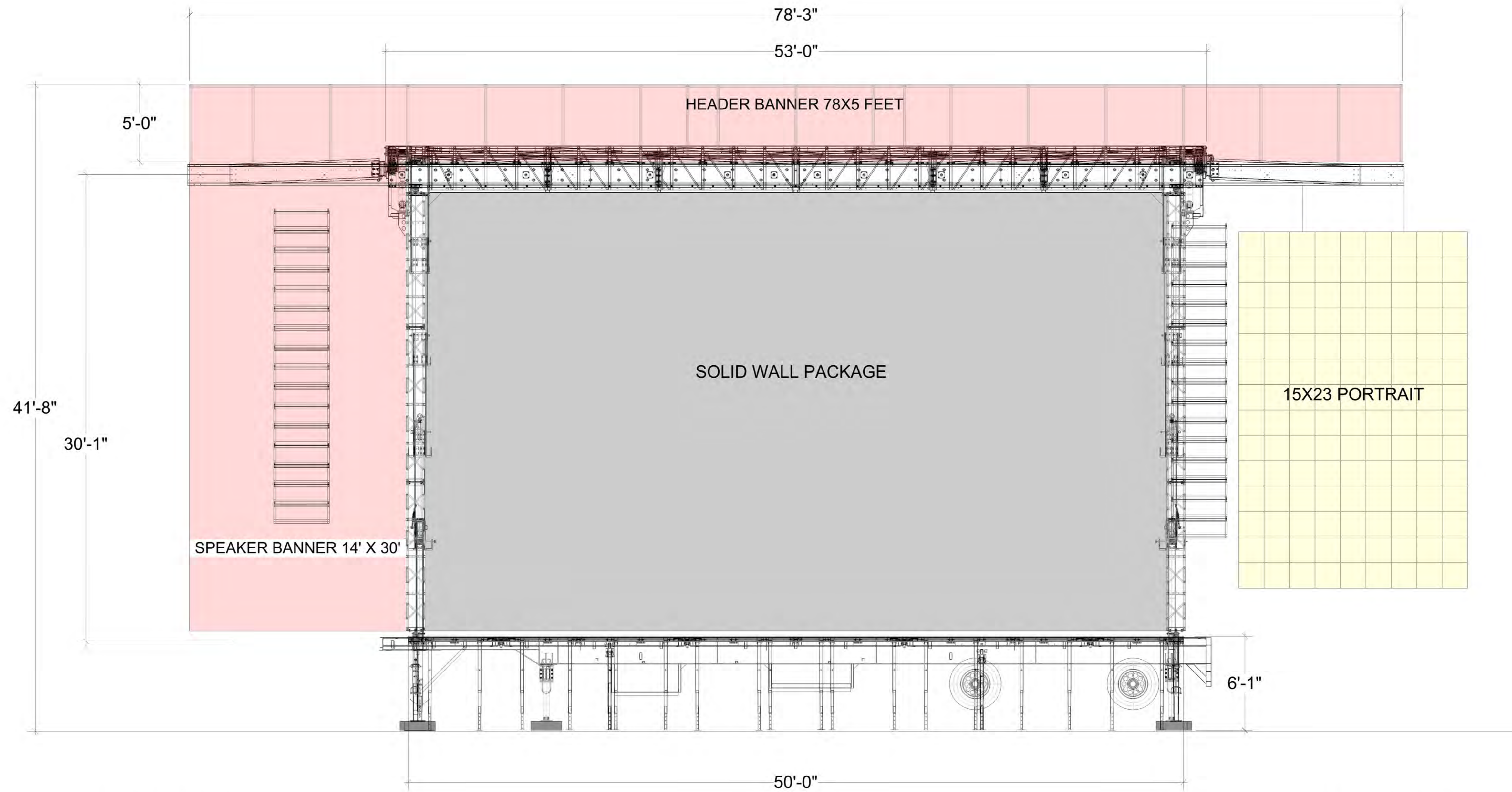

EXAMPLE #1
PA FLOWN ON SLIDE OUT WITH BANNER

EXAMPLE #2
PA ON FRONT HANG WITH VIDEO WALL ON SLIDE OUT

APEX STAGES GEN3 5040

UNFOLDING THE POSSIBILITIES

"BASIC MODE" FRONT VIEW

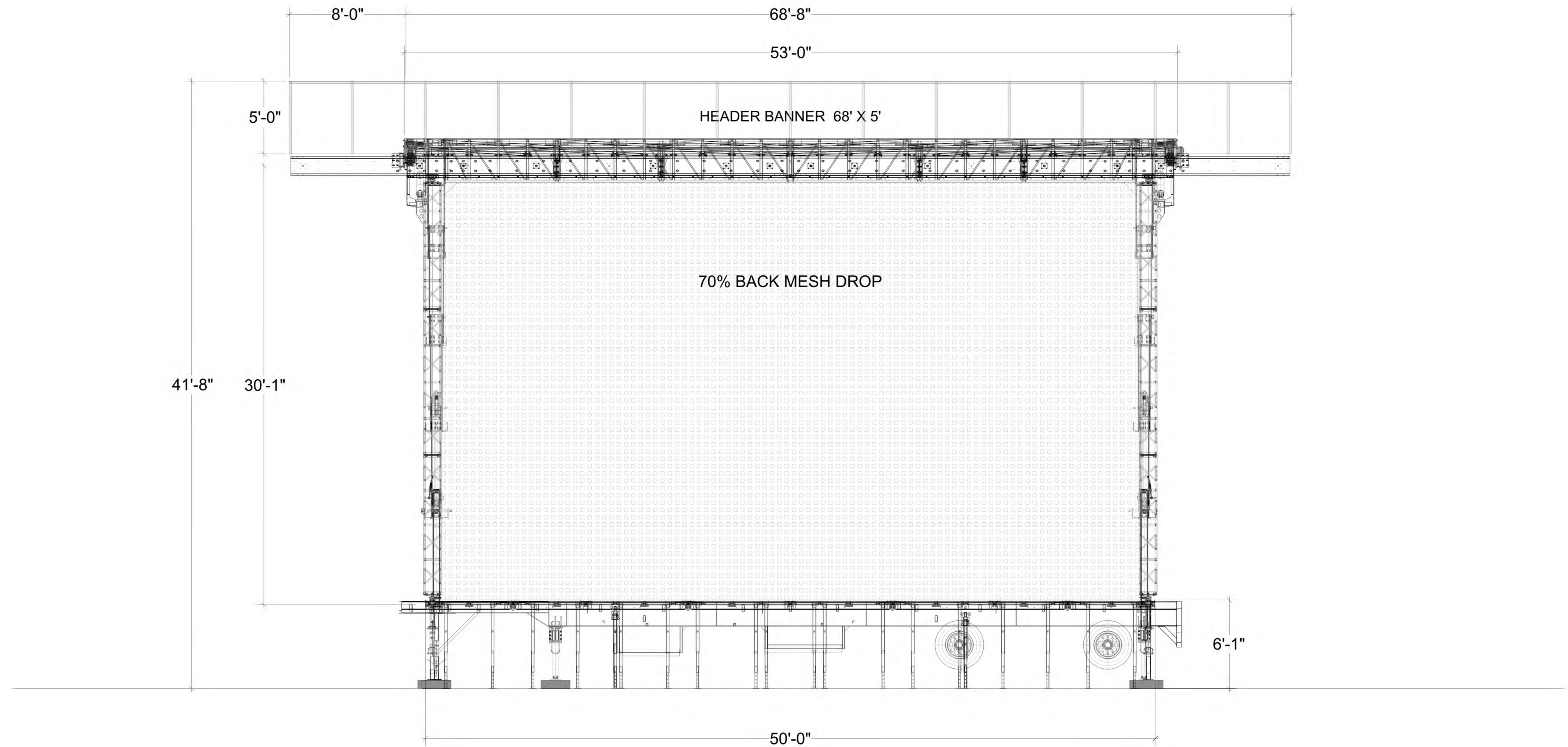

APEX STAGES GEN3 5040

UNFOLDING THE POSSIBILITIES

"BASIC MODE" SIDE VIEW

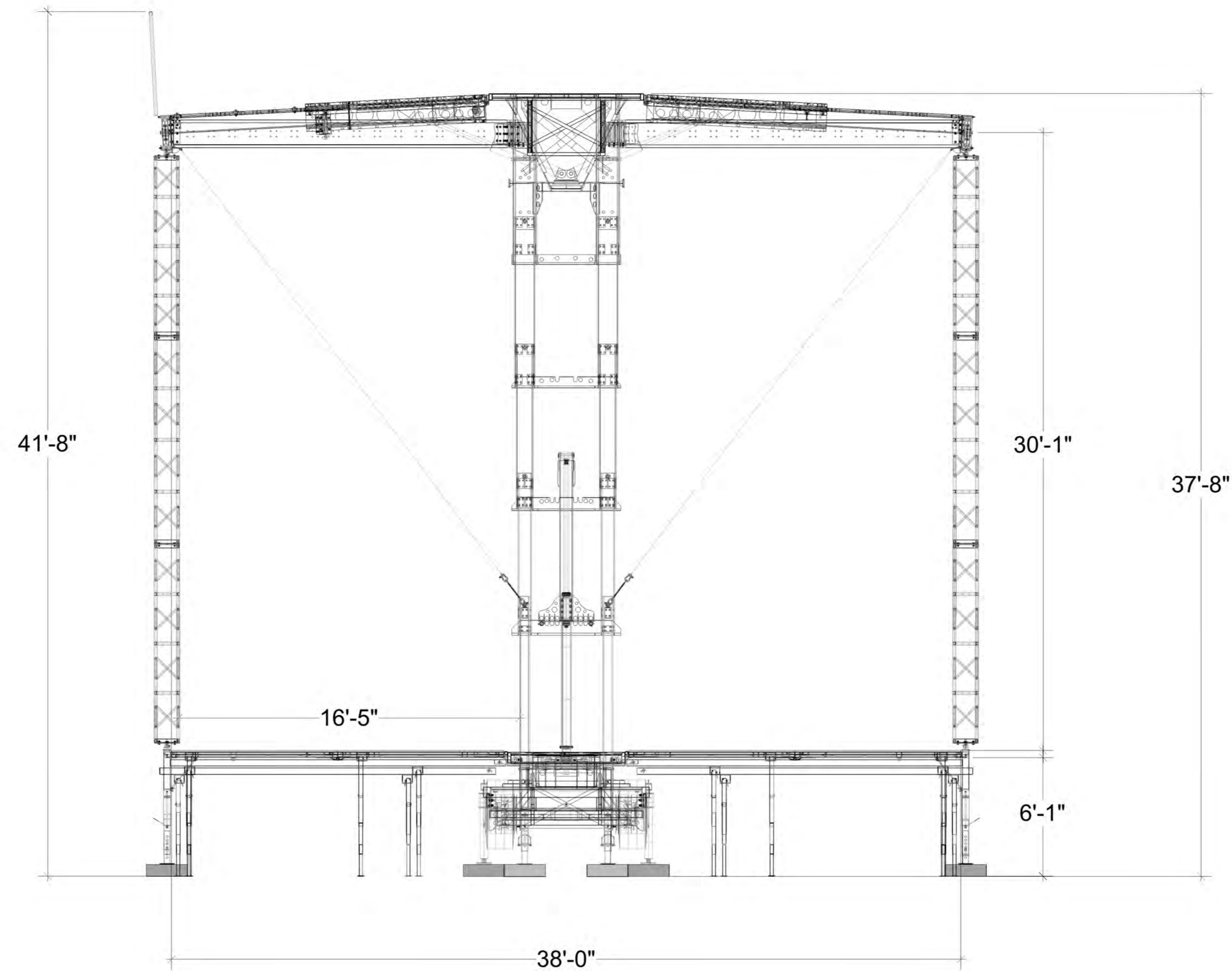

APEX STAGES GEN3 5040

UNFOLDING THE POSSIBILITIES

"BASIC MODE" TOP VIEW
DIMENSIONS AND WEIGHTS

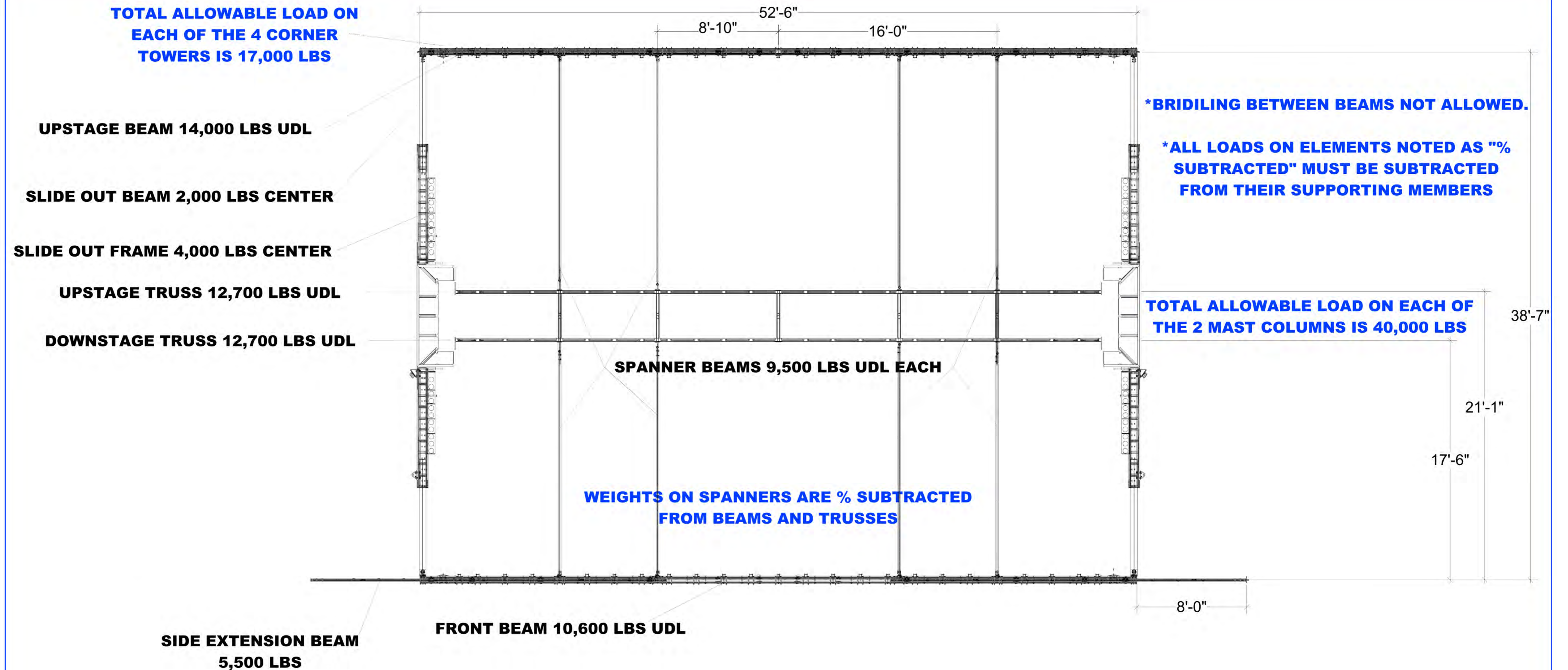

APEX 5040 GEN3 DIMENSIONS AND WIEGHTS
TOTAL WEIGHT CAPACITY OF ROOF STRUCTURE 85,000 LBS
TOTAL WEIGHT CAPCITY OF COLUMNS AND TOWERS 148,000 LBS

APEX STAGES GEN3 5040

UNFOLDING THE POSSIBILITIES

"BASIC MODE" FRONT VIEW
STANDARD CONFIGURATION

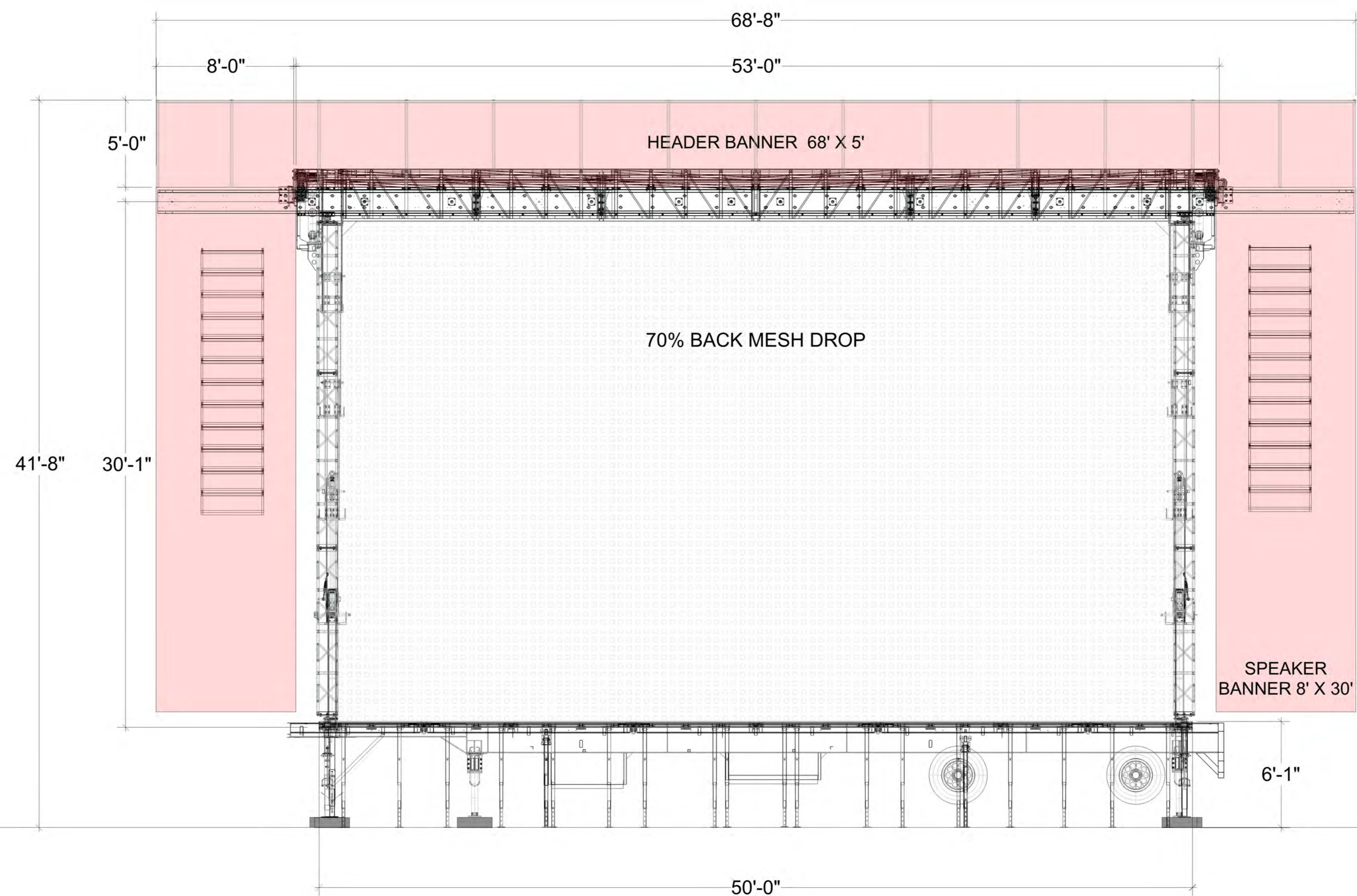

APEX STAGES GEN3 5040

UNFOLDING THE POSSIBILITIES

WEIGHT TO GROUND

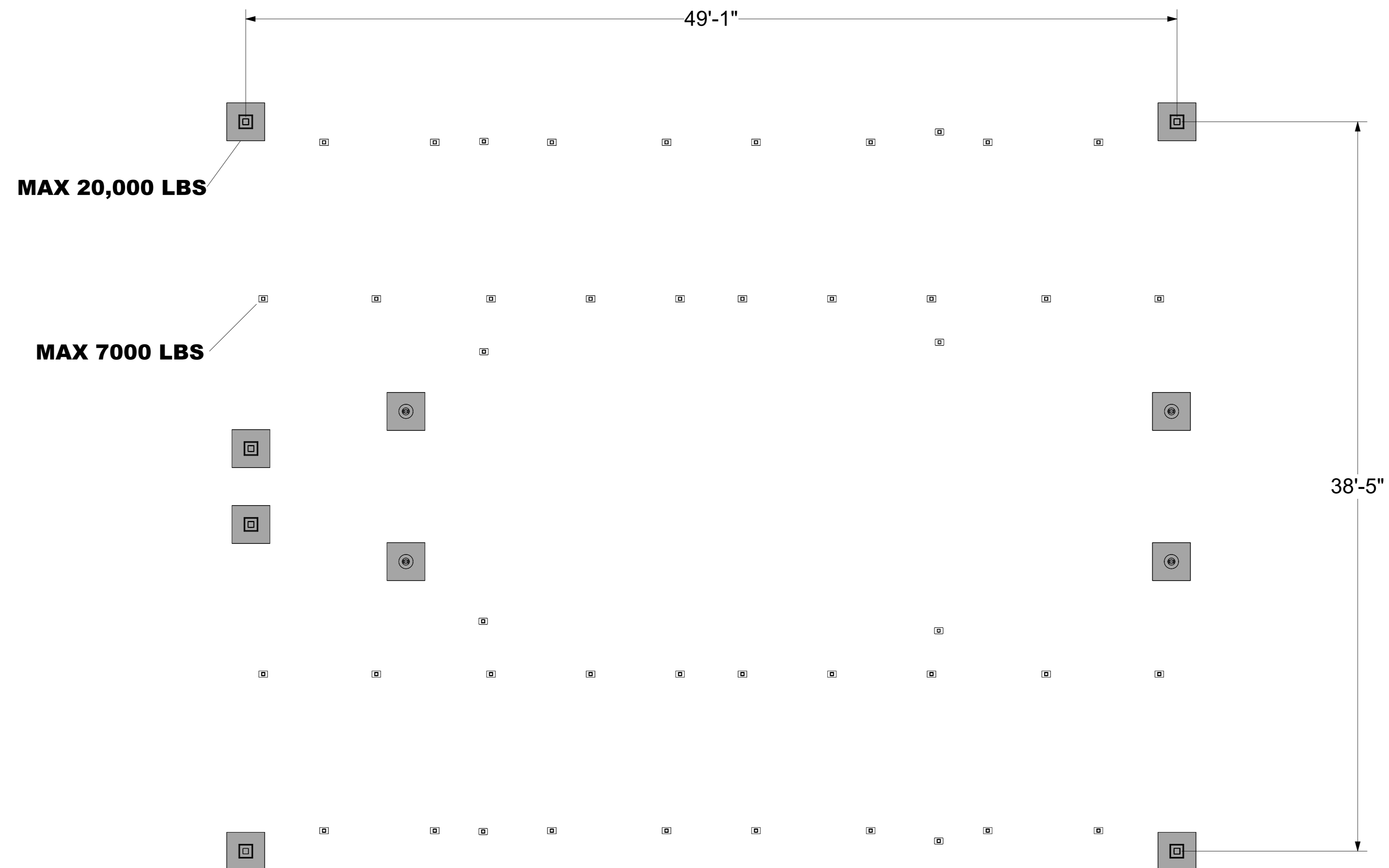

**SHOWN IS MAX WEIGHTS ALLOWABLE AS PER ENGINEERING
TOTAL GROSS WEIGHT OF STRUCTURE IS 60,000 LBS TO BE SPREAD OUT ON POINTS SHOWN
ADDITIONAL WEIGHT WOULD BE DETERMINED WHEN PRODUCTION FIGURES ARE ADDED IN.**